

# ZOOMLION

Distributed by:



## ■ Big Capacity Series Diesel Forklift



## ■ Technical Features

### Safe & Reliable

- Engine is with large torque and capacity, which is powerful and can meet different operation demands.
- Lifting system is equipped with up and down buffer cylinders, which reduce shock and vibration efficiently.
- Hydraulic system is equipped with throttling valve, which makes operation safe and reliable.
- Reinforced mast with wide view design improves efficiency and safety meanwhile enhances anti-force capability.
- The forklifts are nice in appearance with streamline design. They work stably with high efficiency and good grade ability and can be operated in bad working conditions.

### Comfortable & Practical

- Integrated overhead guard is adopted. The canopy is one time stamping part with 5 pieces transparent plastic cover, which receives sufficient light and keeps rain out.
- Big power engine in V type installation can reduce the vibration.
- Scientific ergonomic design makes operation more portable and comfortable. Seat and backrest are adjustable. Steering wheel tilt angle is also adjustable, which leaves more legroom. The portable gearshift is quick to shift and easy to operate
- Reinforced mast with wide view design improves efficiency and safety, meanwhile enhances anti-force capacity.



## ■ Technical Parameters

### ■ Characteristics:

Specifications		FD50Z	FD70Z	FDA0Z
Power	-	Diesel	Diesel	Diesel
Transmission	-	Hydraulic	Hydraulic	Hydraulic
Rated capacity	kg	5000	7000	10000
Center of load	J (mm)	600	600	600
Lifting height	h1 (mm)	3000	3000	3000
Free lifting height	h3 (mm)	203	218	220
Forks (L x W x H)	L5 x W x T (mm)	1220 x 150 x 55	1220 x 150 x 70	1220 x 175 x 80
Tilt forward/backward	°	6/12	6/12	6/12
Min. turning radius	R1 (mm)	3250	3370	3900
Min. ground clearance (Mast)	m (mm)	200	200	250
Overhead guard height	h4 (mm)	2460	2460	2600
Height from seat to overhead guard	L3 (mm)	1050	1050	2600
Front overhang	L4 (mm)	610	625	715

### ■ Performance:

Specifications		FD50Z	FD70Z	FDA0Z
Max. travelling speed (loaded)	km/h	26	26	20
Max. lifting speed (loaded/empty)	mm/s	370/450	370/450	290/350
Drawbar pull/gradeability	kN/%	51.4/20	51.4/20	57/20

### ■ Dimensions:

Specifications		FD50Z	FD70Z	FDA0Z
Overall length (without fork)	L1 (mm)	3431	3466	4260
Overall width	W1 (mm)	2235	2235	2230
Mast lowered height	h2 (mm)	2500	2500	2850
Mast extended height	mm	4417	4417	4335

## Chassis:

Specifications			FD50Z	FD70Z	FDA0Z
Tire	Front	-	8.25-15-14PR	8.25-15-14PR	9.00-20-14PR
	Rear	-	8.25-15-14PR	6.8.25-15-14PR	9.00-20-14PR
Wheelbase	L2 (mm)		2250	2250	2800
Tread width (Front/Rear)	S/P (mm)		1470/1700	1470/1700	1600/1700
Curb weight (None-load)	kg		7980	9340	12500

## Powertrain:

Specifications			FD50Z	FD70Z	FDA0Z
Battery (Voltage/Capacity)	V/Ah		(12/90) x2	(12/90) x2	(12/90) x2
Engine	Model	-	6BG1QC-02	6BG1QC-02	6BG1QC-02
	Rated power	kW/r.p.m	82.4/2000	82.4/2000	82.4/2000
	Rated torque	N·m/r.p.m	416.8/1500	416.8/1500	416.8/1500
	Cylinder amount	-	6	6	6
	Bore x stroke	mm	105 x 125	105 x 125	105 x 125
	Displacement	L	6.494	6.494	6.494
Fuel tank	L		140	140	140
Transmission	-		Automatic	Automatic	Automatic
Working pressure	MPa		20	20	20

Standard configuration				Options	Attachment	
<ul style="list-style-type: none"> <li>• Wideview mast</li> <li>• Standard fork</li> <li>• Standard seat</li> <li>• Handle</li> <li>• Timer</li> <li>• Backrest</li> <li>• Light switch</li> <li>• Toolbox</li> <li>• Rubber pad</li> <li>• Tornado air filter</li> </ul>	<ul style="list-style-type: none"> <li>• 2 piece multi valve</li> <li>• Rear lamp</li> <li>• Neutral indicator</li> <li>• Electric horn</li> <li>• Turning signal</li> <li>• Service brake</li> <li>• Traction pin</li> <li>• Headlamp</li> <li>• Parking brake</li> <li>• Rearview mirror</li> </ul>	<ul style="list-style-type: none"> <li>• Speed limit valve</li> <li>• Engine flameout device</li> <li>• Oil pressure indicator</li> <li>• Durable pneumatic tire</li> <li>• Key switch</li> <li>• Overhead guard</li> <li>• Reversing light</li> <li>• Reversing buzzer</li> <li>• Hydraulic oil return filter</li> <li>• Hydraulic oil intake filter</li> </ul>	<ul style="list-style-type: none"> <li>• Hydraulic powered steering</li> <li>• Adjustable steering wheel</li> <li>• Upper air intake device</li> <li>• Tilt oil passage self-locking valve</li> <li>• Water temperature gauge</li> <li>• Combined instrument panel</li> <li>• Hydraulic oil level gauge</li> <li>• Lifting &amp; tilting handle</li> </ul>	<ul style="list-style-type: none"> <li><input type="checkbox"/> Cab</li> <li><input type="checkbox"/> Heater</li> <li><input type="checkbox"/> Solid tyre</li> <li><input type="checkbox"/> Rear light</li> <li><input type="checkbox"/> Mini fan</li> <li><input type="checkbox"/> Double filter</li> <li><input type="checkbox"/> File clip</li> <li><input type="checkbox"/> Windshield</li> <li><input type="checkbox"/> Luxury seat</li> <li><input type="checkbox"/> High exhaust</li> </ul>	<ul style="list-style-type: none"> <li><input type="checkbox"/> Fire extinguishing muffler</li> <li><input type="checkbox"/> Rotary work alarming light</li> <li><input type="checkbox"/> Fire extinguisher</li> <li><input type="checkbox"/> Engine preheater</li> <li><input type="checkbox"/> Optional painting</li> <li><input type="checkbox"/> Tilt cylinder dust cover</li> <li><input type="checkbox"/> Two/three stage full-free mast</li> <li><input type="checkbox"/> Double front tire and protector</li> <li><input type="checkbox"/> Exhaust smoke purification muffler</li> </ul>	<ul style="list-style-type: none"> <li><input type="checkbox"/> Side shifter</li> <li><input type="checkbox"/> Fork positioner</li> <li><input type="checkbox"/> Hinged fork</li> <li><input type="checkbox"/> Carpet boom</li> <li><input type="checkbox"/> Extended fork</li> <li><input type="checkbox"/> Fork cover</li> <li><input type="checkbox"/> Lifting boom</li> <li><input type="checkbox"/> Paper roll clamp</li> <li><input type="checkbox"/> Bare clamp</li> <li><input type="checkbox"/> Rotator</li> <li><input type="checkbox"/> Barrel clamp</li> </ul>

## ■ 2D Graph

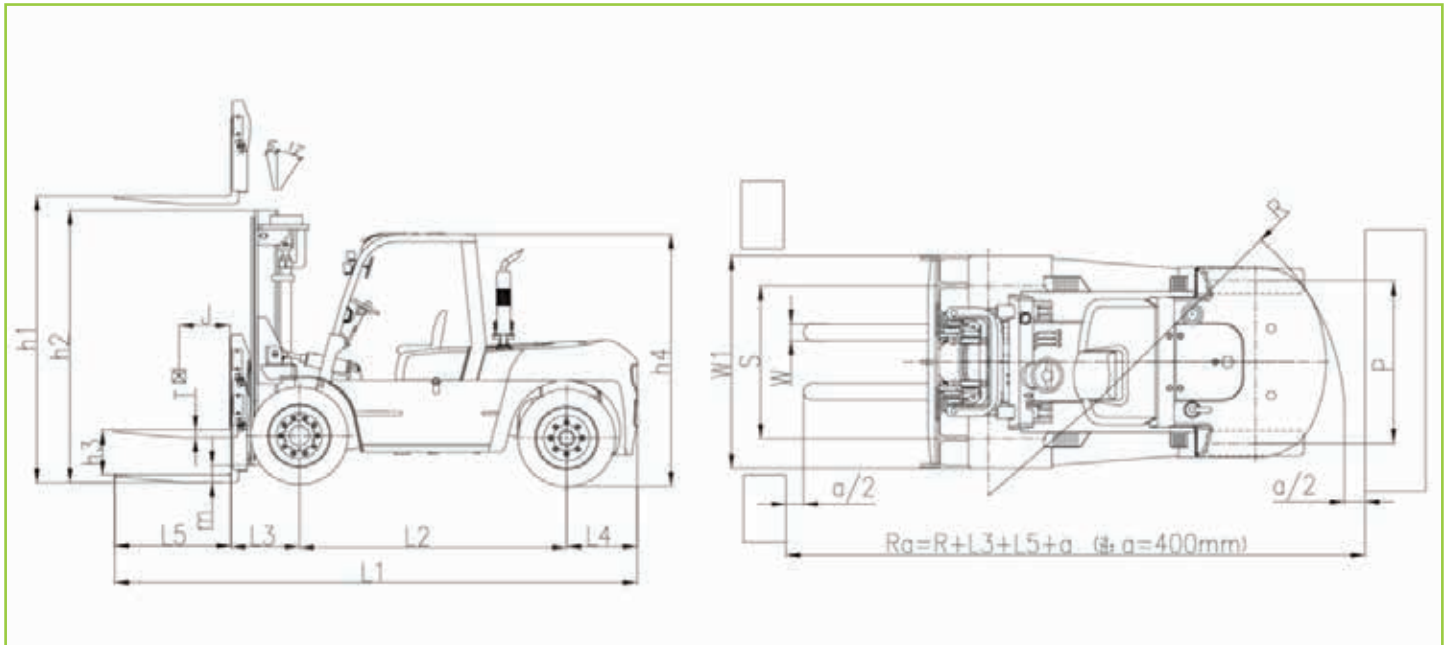

This document is not contractual - The **TANEKO**<sup>®</sup> company reserves the right to modify any of the characteristics stated in this document without notice, in a constant effort to improve the quality of its products. \*ISO 8528.

Weights and dimensions based on standard products. Illustrations may include optional equipment.  
Technical data described in this catalogue correspond to the available information at the moment of printing.



### PT. Tan Energy Indonesia (TANEKO)

Alamanda Tower Lt. 28-D  
Jl. TB Simatupang Kav. 23-24, Cilandak Barat  
Jakarta 12430 - INDONESIA  
Ph.: (+62-21) 7590 5072 / 7590 5073  
Email: [marketing@taneko.co.id](mailto:marketing@taneko.co.id)  
Website: [www.taneko.co.id](http://www.taneko.co.id)